



EMMS - Release FAQ – January 2019

1.00 Final December 2018

Release series: EMMS082018MP5F

Important notice

PURPOSE & AUDIENCE

This document describes the technical changes required to participant's systems for the January 2019. The Australian Energy Market Operator (AEMO) provides this information as a service targeting business analysts and IT staff in participant organisations. It provides guidance about the changes to their market systems under the National Gas or Electricity Rules (Rules), as at the date of publication.

HOW TO USE THIS DOCUMENT

- If you have questions about the business aspects of these changes, please see Consultations on AEMO's website.
- The references listed throughout this document are primary resources and take precedence over this document.
- Unless otherwise stated, you can find resources mentioned in this guide on AEMO's website.
- **Text in this format**, indicates a reference to a document on AEMO's website.
- This document is written in plain language for easy reading. Where there is a discrepancy between the Rules and information or a term in this document, the Rules take precedence.
- Glossary Terms are capitalised and have the meanings listed against them in the Glossary.
- *Italicised terms* are defined in the Rules. Any rules terms not in this format still have the same meaning.

PRIVACY AND LEGAL NOTICES

The material in this publication may be used in accordance with the privacy and legal notices on AEMO's website.

TRADEMARK NOTICES

Microsoft, Windows and SQL Server are either registered trademarks or trademarks of Microsoft Corporation in the United States and/or other countries.

Oracle and Java are registered trademarks of Oracle and/or its affiliates.

UNIX is a registered trademark of The Open Group in the US and other countries.

© 2015 Google Inc, used with permission. Google and the Google logo are registered trademarks of Google Inc.

DISTRIBUTION

Available to the public.

DOCUMENT IDENTIFICATION

Prepared by: AEMO Market Systems

Last update: Thursday, 6 December 2018 12:09:00

VERSION HISTORY

1.00 Initial release

DOCUMENTS MADE OBSOLETE

The release of this document changes only the version of EMMS - Release FAQ – January 2019.

FURTHER INFORMATION

For further information, please visit AEMO's website www.aemo.com.au or contact:

AEMO Information and Support Hub Phone: 1300 AEMO 00 (1300 236 600) and follow the prompts. Email: supporthub@aemo.com.au

FEEDBACK

Your feedback is important and helps us improve our services and products. To suggest improvements, please contact AEMO's Support Hub.

Contents

1.	P5MIN	1
1.1	What if I do not upgrade my P5MIN tables?	1
2.	PASA	1
2.1	Will the source of the MTPASA data change even if I don't upgrade?	1
3.	PDR Monitor	1
3.1	Do I have to upgrade to pdrMonitor from Replication Manager?	1
3.2	Does it matter which Data Model version I have to run pdrMonitor?	1
3.3	Will Replication Manager still work?	1
3.4	Are the v7.3 versions of pdrBatcher and pdrLoader still supported?	1
3.5	Can I run independent pdrLoader instances to populate separate Electricity and Gas Data Models for a single Participant ID?	2
3.6	Does the pdrMonitor rely on a polling process?	2
3.7	Can you have a higher polling for high priority threads?.....	2
3.8	Will the pdrMonitor allow changes to Data Subscriptions in the application?.....	2
3.9	Will the pdrMonitor have the re-request reports function?	2
3.10	How am I impacted if I have a bespoke configuration or setup?	2
4.	Data Interchange	3
4.1	What is the November release for EMMS?.....	3
4.2	Which platforms are supported for this Release?	3
5.	Data Model	4
5.1	What are the current Data Model versions?	4
5.2	Do I have to upgrade my Data Model?.....	4
5.3	When can I upgrade my Data Model?.....	4
5.4	What if there is a delay to the release?	4
5.5	When will AEMO release the scripts?.....	4
5.6	Where can I find the scripts?.....	4
5.7	Do I need to subscribe to the new reports?.....	4
5.8	How do I subscribe to new Data Model files?.....	5
6.	Related resources	6

1. P5MIN

1.1 What if I do not upgrade my P5MIN tables?

You will not see a change.

2. PASA

2.1 Will the source of the MTPASA data change even if I don't upgrade?

No, only the STPASA source will change even if you don't upgrade your Data Model. The MT PASA source does not change.

3. PDR Monitor

3.1 Do I have to upgrade to pdrMonitor from Replication Manager?

No, but the Replication Manager software is no longer supported by AEMO.

3.2 Does it matter which Data Model version I have to run pdrMonitor?

No.

3.3 Will Replication Manager still work?

Yes, but it is no longer supported by AEMO.

3.4 Are the v7.3 versions of pdrBatcher and pdrLoader still supported?

No. Testing is only on the v7.4 versions now.

3.5 Can I run independent pdrLoader instances to populate separate Electricity and Gas Data Models for a single Participant ID?

Yes, the manifest request process caters for multiple markets.

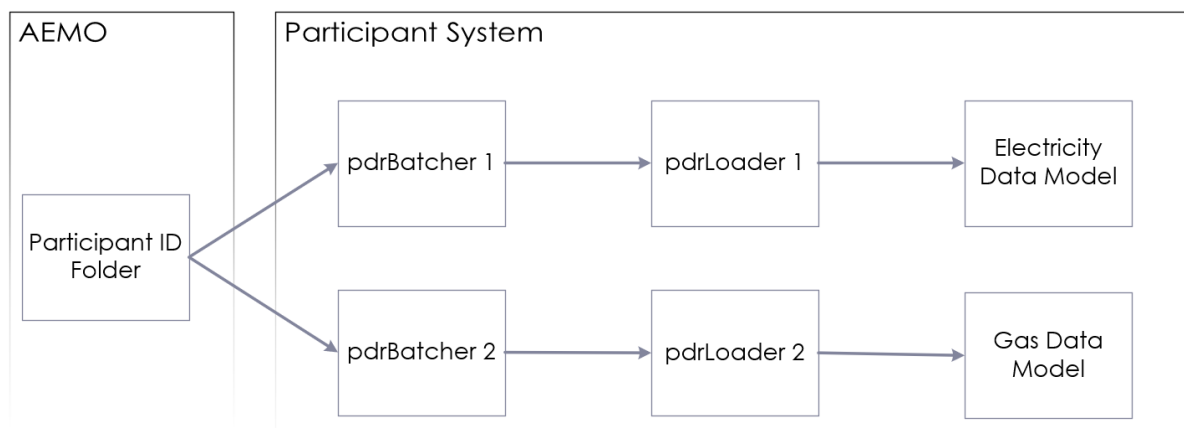

3.6 Does the pdrMonitor rely on a polling process?

The pdrMonitor has a polling cycle running in the background to collect performance and logging data from the pdrBatcher and pdrLoader applications.

3.7 Can you have a higher polling for high priority threads?

No, because the polling is global.

PDR Loader 7.4.1 introduces directory notification services where the files are picked up immediately.

3.8 Will the pdrMonitor allow changes to Data Subscriptions in the application?

Currently no, but please send enhancement suggestions to the Support Hub for consideration.

3.9 Will the pdrMonitor have the re-request reports function?

Yes, this feature is included.

3.10 How am I impacted if I have a bespoke configuration or setup?

Participants having Data Model and Data Interchange setups that do not conform to the standard Data Model or standard Data Interchange setup cannot make assumptions about either column or row order in the CSV files we produce.

We target our transition strategy towards participants who operate a standard environment using the software AEMO provides. For more details, see **Guide to setting up a standard Data Interchange environment**.

Participants using bespoke setups need to manage these transition issues within their own solution. We recommend participants with bespoke setups pay close attention to Technical Specifications that document the changes.

The Data Interchange software AEMO provides operates in this manner:

- Always interpret column order from the “I” informational record and by looking up the relevant columns by name.
- Always consider row order from the corresponding “D” data records as random.

4. Data Interchange

4.1 What is the November release for EMMS?

The November Release is the Data Interchange Participant Data Replication (PDR) products release. The release is to support compatibility between the PDR Batchter, Loader, and Monitor.

Participants do not need to upgrade their Data Models for this release.

Software	Current version	Still supported
PDR Loader	7.4.1	7.4
PDR Batchter	7.4.1	7.4
PDR Monitor	1.0	n/a

For more details, see [AEMO Help Desk Bulletin No. 2103: EMMS Release Schedule - Data Interchange Upgrade - 2017-2018](#).

4.2 Which platforms are supported for this Release?

	Current	Still supported
Microsoft SQL Server	2014	2012
Oracle	12c	11g

5. Data Model

5.1 What are the current Data Model versions?

- Electricity 4.27, 4.28 (January 2019)
- Gas 2.0, 2.01 (March 2019)

5.2 Do I have to upgrade my Data Model?

Yes, if you want to see the new data in the tables.

5.3 When can I upgrade my Data Model?

Participants upgrade their Data Models after the AEMO's communication advising the AEMO implementation is complete and before the next Data Model release.

5.4 What if there is a delay to the release?

If there is a delay to the release AEMO will send a communication advising of the problem and a new date and time for the release.

5.5 When will AEMO release the scripts?

We expect to release the scripts for participant review 4 December 2018. For more details, see the **EMMS Release Schedule & Technical Specification – Jan 2019 Electricity Data Model v4.28**.

5.6 Where can I find the scripts?

FTP to the Participant File Server: [146.178.211.25 > Releases > Gas or MMS Data Model > Pre-production](#).

5.7 Do I need to subscribe to the new reports?

- No, if you are currently subscribed you are automatically subscribed to the new reports.
- Yes, if you are not currently subscribed.

Sometimes this depends on the report and some releases might include a mix of automated and voluntary subscriptions. Refer to the relevant technical specification to confirm your subscriptions match the Data Model you are installing.

5.8 How do I subscribe to new Data Model files?

- For help subscribing to Gas Data Model files, follow the steps in this document: http://aemo.com.au/-/media/Files/Gas/IT_Systems/2017/Subscribing-to-new-Gas-Data-Model-files.pdf
- For help subscribing to Electricity Data Model files, follow the steps in: [Guide to Data Subscription](#).

6. Related resources

Data Interchange software and associated documentation:

1. Releases directory on the participant file share: FTP to 146.178.211.25 > Data Interchange, pdrBatcher, pdrLoader, and pdrMonitor.
2. Data Subscription web application in the Markets Portal:
 - Production: <https://portal.prod.nemnet.net.au>
 - Pre-production: <https://portal.preprod.nemnet.net.au>

Guide to Data Subscription: <http://aemo.com.au/-/media/Files/Electricity/NEM/IT-Systems-and-Change/2017/Guide-to-Data-Subscription.pdf>

Guide to upgrading a standard Data Interchange environment: <http://aemo.com.au/-/media/Files/Electricity/NEM/IT-Systems-and-Change/2016/Guide-to-Upgrading-a-Standard-Data-Interchange-Environment.pdf>

Release Schedules, Technical Specifications, FAQs, and Meeting Minutes:

- Electricity: <http://aemo.com.au/Electricity/IT-Systems/IT-change> > Release Schedules
- Gas: <http://aemo.com.au/Gas/IT-systems-and-change/IT-change> > Release Schedules

Subscribing to Gas Data Model Files: http://aemo.com.au/-/media/Files/Gas/IT_Systems/2017/Subscribing-to-new-Gas-Data-Model-files.pdf